

# Minimization of Boolean Functions\*

E. J. McCLUSKEY, Jr.

(Manuscript received June 26, 1956)

*A systematic procedure is presented for writing a Boolean function as a minimum sum of products. This procedure is a simplification and extension of the method presented by W. V. Quine. Specific attention is given to terms which can be included in the function solely for the designer's convenience.*

## 1 INTRODUCTION

In designing switching circuits such as digital computers, telephone central offices, and digital machine tool controls, it is common practice to make use of Boolean algebra notation.<sup>1, 2, 3, 4</sup> The performance of a single-output circuit is specified by means of a Boolean function of the input variables. This function, which is called the circuit transmission, is equal to 1 when an output is present and equals 0 when there is no output. A convenient means of specifying a transmission is a table of combinations such as that given in Table I. This table lists, in the column under T, the output condition for each combination of input conditions. If there are some combinations of input conditions for which the output is not specified (perhaps because these combinations can never occur), d-entries are placed in the T-column of the corresponding rows of the table of combinations. The actual values (0 or 1) assigned to these rows are usually chosen so as to simplify the circuit which is designed to satisfy the requirements specified in the table of combinations.

For each row of the table of combinations a transmission can be written which equals "one" only when the variables have the values listed in that row of the table. These transmissions will be called *elementary product terms* (or more simply, p-terms) since any transmission can always be written as a sum of these p-terms. Table I (b) lists the p-terms for Table I(a). Note that every variable appears in each p-term. The

---

\* This paper is derived from a thesis submitted to the Massachusetts Institute of Technology in partial fulfillment of the requirements for the degree of Doctor of Science on April 30, 1956.

TABLE I — CIRCUIT SPECIFICATIONS

(a) Table of Combinations				(b) p-terms	
	$x_1$	$x_2$	$x_3$	$T$	
0	0	0	0	0	$x_1' x_2' x_3'$
1	0	0	1	1	$x_1' x_2' x_3$
2	0	1	0	1	$x_1' x_2 x_3'$
3	0	1	1	1	$x_1' x_2 x_3$
4	1	0	0	1	$x_1 x_2' x_3'$
5	1	0	1	1	$x_1 x_2' x_3$
6	1	1	0	1	$x_1 x_2 x_3'$
7	1	1	1	0	$x_1 x_2 x_3$

## (c) Canonical Expansion

$$T = x_1'x_2'x_3 + x_1'x_2x_3' + x_1'x_2x_3 + x_1x_2'x_3' + x_1x_2'x_3 + x_1x_2x_3'$$

p-term corresponding to a given row of a table of combinations is formed by priming any variables which have a "zero" entry in that row of the table and by leaving unprimed those variables which have "one" entries. It is possible to write an algebraic expression for the over-all circuit transmission directly from the table of combinations. This over-all transmission,  $T$ , is the sum of the p-terms corresponding to those rows of the table of combinations for which  $T$  is to have the value "one." See Table I(c). Any transmission which is a sum of p-terms is called a *canonical expansion*.

The decimal numbers in the first column of Table I(a) are the decimal equivalents of the binary numbers formed by the entries of the table of combinations. A concise method for specifying a transmission function is to list the decimal numbers of those rows of the table of combinations for which the function is to have the value one. Thus the function of Table I can be specified as  $\sum(1, 2, 3, 4, 5, 6)$ .

One of the most basic problems of switching circuit theory is that of writing a Boolean function in a simpler form than the canonical expansion. It is frequently possible to realize savings in equipment by writing a circuit transmission in simplified form. Methods for expressing a Boolean function in the "simplest" sum of products form were published by Karnaugh,<sup>1</sup> Aiken,<sup>5</sup> and Quine.<sup>6</sup> These methods have the common property that they all fail when the function to be simplified is reasonably complex. The following sections present a method for simplifying functions which can be applied to more complex functions than previous methods, is systematic, and can be easily programmed on a digital computer.

## 2 THE MINIMUM SUM

By use of the Boolean algebra theorem  $x_1x_2 + x_1'x_2 = x_2$  it is possible to obtain from the canonical expansion other equivalent sum functions:

that is, other sum functions which correspond to the same table of combinations. These functions are still sums of products of variables but not all of the variables appear in each term. For example, the transmission of Table I,  $T = x_1'x_2'x_3 + x_1'x_2x_3' + x_1'x_2x_3 + x_1x_2'x_3' + x_1x_2'x_3 + x_1x_2x_3' = (x_1'x_2'x_3 + x_1'x_2x_3) + (x_1'x_2x_3' + x_1x_2x_3') + (x_1x_2'x_3' + x_1x_2'x_3) = (x_1'x_2'x_3 + x_1x_2'x_3) + (x_1'x_2x_3' + x_1'x_2x_3) + (x_1x_2'x_3' + x_1x_2x_3')$  can be written as either  $T = x_1'x_3 + x_2x_3' + x_1x_2'$  or  $T = x_2'x_3 + x_1'x_2 + x_1x_3'$ .

A *literal* is defined as a variable with or without the associated prime ( $x_1, x_2'$  are literals). The sum functions which have the fewest terms of all equivalent sum functions will be called *minimum sums* unless these functions having fewest terms do not all involve the same number of literals. In such cases, only those functions which involve the fewest literals will be called minimum sums. For example, the function

$$T = \sum(7, 9, 10, 12, 13, 14, 15)$$

can be written as either

$$T = x_4x_2x_1' + x_3x_2x_1 + x_4x_2'x_1 + x_4x_3x_1'$$

or as

$$T = x_4x_2x_1' + x_3x_2x_1 + x_4x_2'x_1 + x_4x_3$$

Only the second expression is a minimum sum since it involves 11 literals while the first expression involves 12 literals.

The minimum sum defined here is not necessarily the expression containing the fewest total literals, or the expression leading to the most economical two-stage diode logic circuit,<sup>1</sup> even though these three expressions are identical for many transmissions. The definition adopted here lends itself well to computation and results in a form which is useful in the design of contact networks. A method is presented in Section 9 for obtaining directly the expressions corresponding to the optimum two-stage diode logic circuit or the expressions containing fewest literals.

In principle it is possible to obtain a minimum sum for any given transmission by enumerating all possible equivalent sum functions then selecting those functions which have the fewest terms, and finally selecting from these the functions which contain fewest literals. Since the number of equivalent sum functions may be quite large, this procedure is not generally practical. The following sections present a practical method for obtaining a minimum sum without resorting to an enumeration of all equivalent sum functions.

### 3 PRIME IMPLICANTS

When the theorem  $x_1x_2 + x_1x_2' = x_1$  is used to replace by a single term, two  $p$ -terms, which correspond to rows  $i$  and  $j$  of a table of combi-

nations, the resulting term will equal "one" when the variables have values corresponding to either row  $i$  or row  $j$  of the table. Similarly, when this theorem is used to replace, by a single term, a term which equals "one" for rows  $i$  and  $j$  and a term which equals "one" for rows  $k$  and  $m$ , the resulting term will equal "one" for rows  $i, j, k$  and  $m$  of the table of combinations. A method for obtaining a minimum sum by repeated application of this theorem ( $x_1x_2' + x_1x_2 = x_1$ ) was first presented by Quine.<sup>6</sup> In this method, the theorem is applied to all possible pairs of  $p$ -terms, then to all possible pairs of the terms obtained from the  $p$ -terms, and so on, until no further applications of the theorem are possible. It may be necessary to pair one term with several other terms in applying this theorem. In Example 3.2 the theorem is applied to the terms labeled 5 and 7 and also to the terms labeled 5 and 13. All terms paired with other terms in applying the theorem are then discarded. The remaining terms are called *prime implicants*.<sup>6</sup> Finally a minimum sum is formed as the sum of the fewest prime implicants which when taken together will equal "one" for all required rows of the table of combinations. The terms in the minimum sum will be called *minimum sum terms* or *ms-terms*.

*Example 3.1*

$$T = \sum(3, 7, 8, 9, 12, 13)$$

Canonical Expansion:

$$T = x_1'x_2'x_3x_4 + x_1'x_2x_3x_4 + x_1x_2'x_3'x_4' + x_1x_2'x_3'x_4$$

$$\begin{bmatrix} 0 & 0 & 1 & 1 \\ & & & 3 \end{bmatrix} \begin{bmatrix} 0 & 1 & 1 & 1 \\ & & & 7 \end{bmatrix} \begin{bmatrix} 1 & 0 & 0 & 0 \\ & & & 8 \end{bmatrix} \begin{bmatrix} 1 & 0 & 0 & 1 \\ & & & 9 \end{bmatrix}$$

$$+ x_1x_2x_3'x_4' + x_1x_2x_3'x_4$$

$$\begin{bmatrix} 1 & 1 & 0 & 0 \\ & & & 12 \end{bmatrix} \begin{bmatrix} 1 & 1 & 0 & 1 \\ & & & 13 \end{bmatrix}$$

The bracketed binary and decimal numbers below the sum terms indicate the rows of the table of combinations for which the corresponding term will equal "one." A binary character in which a dash appears represents the two binary numbers which are formed by replacing the dash by a "0" and then by a "1." Similarly a binary character in which two dashes appear represents the four binary numbers formed by replacing the dashes by "0" and "1" entries, etc.

$$x_1'x_2'x_3x_4 + x_1'x_2x_3x_4 = x_1'x_3x_4$$

$$\begin{bmatrix} 0 & 0 & 1 & 1 \\ & & & 3 \end{bmatrix} \begin{bmatrix} 0 & 1 & 1 & 1 \\ & & & 7 \end{bmatrix} \begin{bmatrix} 0 & - & 1 & 1 \\ & & & 3,7 \end{bmatrix}$$



$$\begin{aligned}
 x_1x_2'x_3'x_4' + x_1x_2'x_3x_4 &= x_1x_2'x_3' \\
 \begin{bmatrix} 1 & 0 & 0 & 0 \\ & & & 8 \end{bmatrix} & \begin{bmatrix} 1 & 0 & 0 & 1 \\ & & & 9 \end{bmatrix} & \begin{bmatrix} 1 & 0 & 0 & - \\ & & & 8,9 \end{bmatrix} \\
 x_1x_2x_3'x_4' + x_1x_2x_3x_4 &= x_1x_2x_3' \\
 \begin{bmatrix} 1 & 1 & 0 & 0 \\ & & & 12 \end{bmatrix} & \begin{bmatrix} 1 & 1 & 0 & 1 \\ & & & 13 \end{bmatrix} & \begin{bmatrix} 1 & 1 & 0 & - \\ & & & 12,13 \end{bmatrix} \\
 x_1x_2'x_3' + x_1x_2x_3' &= x_1x_3' \\
 \begin{bmatrix} 1 & 0 & 0 & - \\ & & & 8,9 \end{bmatrix} & \begin{bmatrix} 1 & 1 & 0 & - \\ & & & 12,13 \end{bmatrix} & \begin{bmatrix} 1 & - & 0 & - \\ & & & 8,9,12,13 \end{bmatrix}
 \end{aligned}$$

Prime Implicants:

$$\begin{aligned}
 &x_1x_3', \quad x_1'x_3x_4 \\
 &\begin{bmatrix} 1 & - & 0 & - \\ & & & 8,9,12,13 \end{bmatrix} \begin{bmatrix} 0 & - & 1 & 1 \\ & & & 3,7 \end{bmatrix}
 \end{aligned}$$

Minimum Sum:

$$T = x_1x_3' + x_1'x_3x_4$$

*Example 3.2*

$$T = \sum(5, 7, 12, 13)$$

Canonical Expansion:

$$\begin{aligned}
 T &= x_1'x_2x_3'x_4 + x_1'x_2x_3x_4 + x_1x_2x_3'x_4' + x_1x_2x_3'x_4 \\
 &\begin{bmatrix} 0 & 1 & 0 & 1 \\ & & & 5 \end{bmatrix} \begin{bmatrix} 0 & 1 & 1 & 1 \\ & & & 7 \end{bmatrix} \begin{bmatrix} 1 & 1 & 0 & 0 \\ & & & 12 \end{bmatrix} \begin{bmatrix} 1 & 1 & 0 & 1 \\ & & & 13 \end{bmatrix} \\
 &x_1'x_2x_3'x_4 + x_1'x_2x_3x_4 = x_1'x_2x_4 \\
 &\begin{bmatrix} 0 & 1 & 0 & 1 \\ & & & 5 \end{bmatrix} \begin{bmatrix} 0 & 1 & 1 & 1 \\ & & & 7 \end{bmatrix} \begin{bmatrix} 0 & 1 & - & 1 \\ & & & 5,7 \end{bmatrix} \\
 &x_1'x_2x_3'x_4 + x_1x_2x_3'x_4 = x_2x_3'x_4 \\
 &\begin{bmatrix} 0 & 1 & 0 & 1 \\ & & & 5 \end{bmatrix} \begin{bmatrix} 1 & 1 & 0 & 1 \\ & & & 13 \end{bmatrix} \begin{bmatrix} - & 1 & 0 & 1 \\ & & & 5,13 \end{bmatrix} \\
 &x_1x_2x_3'x_4' + x_1x_2x_3'x_4 = x_1x_2x_3' \\
 &\begin{bmatrix} 1 & 1 & 0 & 0 \\ & & & 12 \end{bmatrix} \begin{bmatrix} 1 & 1 & 0 & 1 \\ & & & 13 \end{bmatrix} \begin{bmatrix} 1 & 1 & 0 & - \\ & & & 12,13 \end{bmatrix}
 \end{aligned}$$

Prime Implicants:

$$\begin{aligned}
 &x_1'x_2x_4, \quad x_2x_3'x_4, \quad x_1x_2x_3' \\
 &\begin{bmatrix} 0 & 1 & - & 1 \\ & & & 5,7 \end{bmatrix} \begin{bmatrix} - & 1 & 0 & 1 \\ & & & 5,13 \end{bmatrix} \begin{bmatrix} 1 & 1 & 0 & - \\ & & & 12,13 \end{bmatrix}
 \end{aligned}$$

Minimum Sum:

$$T = x_1'x_2x_4 + x_1x_2x_3'$$

Quine's method, as illustrated in Examples 3.1 and 3.2, becomes unwieldy for transmissions involving either many variables or many p-terms. This difficulty is overcome by simplifying the notation and making the procedure more systematic. The notation is simplified by discarding the expressions involving literals and using only the binary characters. This is permissible because the expressions in terms of literals can always be regained from the binary characters. The theorem being used to combine terms can be stated in terms of the binary characters as follows: If two binary characters are identical in all positions except one, and if neither character has a dash in the position in which they differ, then the two characters can be replaced by a single character which has a dash in the position in which the original characters differ and which is identical with the original characters in all other positions.

TABLE II — DETERMINATION OF PRIME IMPLICANTS FOR TRANSMISSION

$$T = \sum (0, 2, 4, 6, 7, 8, 10, 11, 12, 13, 14, 16, 18, 19, 29, 30)$$

(a) I		(b) II		(c) III	
$x_5x_4x_3x_2x_1$		$x_5x_4x_3x_2x_1$		$x_5x_4x_3x_2x_1$	
0	0 0 0 0 0 ✓	0 2	0 0 0 - 0 ✓	0 2 4 6	0 0 - - 0 ✓
2	0 0 0 1 0 ✓	0 4	0 0 - 0 0 ✓	0 2 8 10	0 - 0 - 0 ✓
4	0 0 1 0 0 ✓	0 8	0 - 0 0 0 ✓	0 2 16 18	- 0 0 - 0
8	0 1 0 0 0 ✓	0 16	- 0 0 0 0 ✓	0 4 8 12	0 - - 0 0 ✓
16	1 0 0 0 0 ✓				
6	0 0 1 1 0 ✓	2 6	0 0 - 1 0 ✓	2 6 10 14	0 - - 1 0 ✓
10	0 1 0 1 0 ✓	2 10	0 - 0 1 0 ✓	4 6 12 14	0 - 1 - 0 ✓
12	0 1 1 0 0 ✓	2 18	- 0 0 1 0 ✓	8 10 12 14	0 1 - - 0 ✓
18	1 0 0 1 0 ✓	4 6	0 0 1 - 0 ✓		
7	0 0 1 1 1 ✓	4 12	0 - 1 0 0 ✓		
11	0 1 0 1 1 ✓	8 10	0 1 0 - 0 ✓		
13	0 1 1 0 1 ✓	8 12	0 1 - 0 0 ✓		
14	0 1 1 1 0 ✓	16 18	1 0 0 - 0 ✓		
19	1 0 0 1 1 ✓				
29	1 1 1 0 1 ✓	6 7	0 0 1 1 -		
30	1 1 1 1 0 ✓	6 14	0 - 1 1 0 ✓		
		10 11	0 1 0 1 -		
		10 14	0 1 - 1 0 ✓		
		12 13	0 1 1 0 -		
		12 14	0 1 1 - 0 ✓		
		18 19	1 0 0 1 -		
		13 29	- 1 1 0 1		
		14 30	- 1 1 1 0		
		(d) IV			
			$x_5x_4x_3x_2x_1$		
		0 2 4 6 8 10 12 14	0 - - - 0		

The first step in the revised method for determining prime implicants is to list in a column, such as that shown in Table II(a), the binary equivalents of the decimal numbers which specify the function. It is expedient to order these binary numbers so that any numbers which contain no 1's come first, followed by any numbers containing a single 1, etc. Lines should be drawn to divide the column into groups of binary numbers which contain a given number of 1's. The theorem stated above is applied to these binary numbers by comparing each number with all the numbers of the next lower group. Other pairs of numbers need not be considered since any two numbers which are not from adjacent groups must differ in more than one binary digit. For each number which has 1's wherever the number (from the next upper group) with which it is being compared has 1's, a new character is formed according to the theorem. A check mark is placed next to each number which is used in forming a new character. The new characters are placed in a separate column, such as Table II(b), which is again divided into groups of characters which have the same number of 1's. The characters in this new column will each contain one dash.

After each number in the first column has been considered, a similar process is carried out for the characters of column two. Two characters from adjacent groups can be combined if they both have their dashes in the same position and if the character from the lower group has 1's wherever the upper character has 1's. If any combinations are possible the resulting characters are placed in a third column such as Table II(c), and the Column II characters from which the new characters are formed are checked. All the characters in this third column will have two dashes. This procedure is repeated and new columns are formed, Table II(d), until no further combinations are possible. The unchecked characters, which have not entered into any combinations, represent the prime implicants.

Each binary character is labeled with the decimal equivalents of the binary numbers which it represents (see note in Example 3.1). These decimal numbers are arranged in increasing arithmetic order. For a character having one dash this corresponds to the order of its formation: When two binary numbers combine, the second number always contains all the 1's of the first number and one additional 1 so that the second number is always greater than the first. Characters having two dashes can be formed in two ways. For example, the character (0, 2, 4, 6) can be formed either by combining (0, 2) and (4, 6) or by combining (0, 4) and (2, 6) as given in Table III. Similarly, there are three ways in which a character having three dashes can be formed (in Table II the 0, 2, 4,

TABLE III — EXAMPLE OF THE TWO WAYS OF FORMING  
A CHARACTER HAVING TWO DASHES

0	0 0 0 0	0 2	0 0 - 0	0 2 4 6	0 - - 0
		0 4	0 - 0 0	(0 4 2 6	0 - - 0)
2	0 0 1 0				
4	0 1 0 0	2 6	0 - 1 0		
		4 6	0 1 - 0		
6	0 1 1 0				

6, 8, 10, 12, 14 character can be formed from the 0, 2, 4, 6, and 8, 10, 12, 14 characters or the 0, 2, 8, 10, and 4, 6, 12, 14 characters or the 0, 4, 8, 12 and 2, 6, 10, 14 characters), four ways in which a character having four dashes can be formed, etc.

In general, any character can be formed by combining two characters whose labels form an increasing sequence of decimal numbers when placed together. It is possible to shorten the process of determining prime implicants by not considering the combination of any characters whose labels do not satisfy this requirement. For example, in Table II(b) the possibility of combining the (0, 4) character with either the (2, 6), (2, 10) or the (2, 18) character need not be considered. If the process is so shortened, it is not sufficient to place check marks next to the two characters from which a new character is formed; each member of all pairs of characters which would produce the same new character when combined must also receive check marks. More simply, when a new character is formed a check mark is placed next to all characters whose labels contain only decimal numbers which occur in the label of the new character. In Table II, when the (0, 2, 4, 6) character is formed by combining the (0, 2) and (4, 6) characters, check marks must be placed next to the (0, 4) and (2, 6) characters as well as the (0, 2) and (4, 6) characters. If the process is not shortened as just described, the fact that a character can be formed in several ways can serve as a check on the accuracy of the process.

It is possible to carry out the entire process of determining the prime implicants solely in terms of the decimal labels without actually writing the binary characters. If two binary characters can be combined as described in this section, then the decimal label of one can be obtained from the decimal label of the other character by adding some power of two (corresponding to the position in which the two characters differ) to each number in the character's label. For example, in Table IIb the label of the (4, 6)(0 0 1 - 0) character can be obtained by adding  $4 = (2^2)$  to the numbers of the label of the (0, 2)(0 0 0 - 0) character. By searching for decimal labels which differ by a power of two, instead of binary characters which differ in only one position, the prime implicants can be

determined as described above without ever actually writing the binary characters.

#### 4 PRIME IMPLICANT TABLES

The minimum sum is formed by picking the fewest prime implicants whose sum will equal one for all rows of the table of combinations for which the transmission is to equal one. In terms of the characters used in Section 3 this means that each number in the decimal specification of the function must appear in the label of at least one character which corresponds to a ms-term (term of the minimum sum).

The ms-terms are selected from the prime implicants by means of a prime implicant table,\* Table IV. Each column of the prime implicant table corresponds to a row of the table of combinations for which the transmission is to have the value one. The decimal number at the top of each column specifies the corresponding row of the table of combinations. Thus the numbers which appear at the tops of the columns are the same as those which specify the transmission. Each row of the prime implicant table represents a prime implicant. If a prime implicant equals "one" for a given row of the table of combinations, a cross is placed at the intersection of the corresponding row and column of the prime implicant table. All other positions are left blank. The table can be written directly from the characters obtained in Section 3 by identifying each row of the table with a character and then placing a cross in each column whose number appears in the label of the character.

It is convenient to arrange the rows in the order of the number of crosses they contain, with those rows containing the most crosses at the top of the table. Also, horizontal lines should be drawn partitioning the table into groups of rows which contain the same number of crosses, Table IV. If, in selecting the rows which are to correspond to ms-terms, a choice between two equally appropriate rows is required, the row having more crosses should be selected. The row with more crosses has fewer literals in the corresponding prime implicant. This choice is more obvious when the table is partitioned as suggested above.

A minimum sum is determined from the prime implicant table by selecting the fewest rows such that each column has a cross in at least one selected row. The selected rows are called *basis rows*, and the prime implicants corresponding to the basis rows are the ms-terms. If any column has only one entry, the row in which this entry occurs must be a basis row. Therefore the first step in selecting the basis rows is to place

\* This table was first discussed by Quine.<sup>6</sup> However, no systematic procedure for obtaining a minimum sum from the prime implicant table was presented.

TABLE IV — PRIME IMPLICANT TABLE FOR THE TRANSMISSION OF TABLE II

	0	2	4	8	16	6	10	12	18	7	11	13	14	19	29	30	
A	x	x	x	x		x	x	x						x			*
B	x	x			x				x								*
C													x			x	*
D										x					x		*
E								x									*
F									x								*
G						x											*
H										x							*

an asterisk next to each row which contains the sole entry of any column (rows A, B, C, D, E, G, H, in Table IV). A line is then drawn through all rows marked with an asterisk and through *all* columns in which these rows have entries. This is done because the requirement that these columns have entries in at least one basis row is satisfied by selecting the rows marked with an asterisk as basis rows. When this is done for Table IV, all columns are lined out and therefore the rows marked with asterisks are the basis rows for this table. Since no alternative choice of basis rows is possible, there is only one minimum sum for the transmission described in this table.

5 ROW COVERING

In general, after the appropriate rows have been marked with asterisks and the corresponding columns have been lined out, there may remain some columns which are not lined out; for example, column 7 in Table V(b). When this happens, additional rows must be selected and the columns in which these rows have entries must be lined out until all columns of the table are lined out. For Table V(b), the selection of either row B or row F as a basis row will cause column 7 to be lined out. However, row B is the correct choice since it has more crosses than row F. This is an example of the situation which was described earlier in connection with the partitioning of prime implicant tables. Row B is marked with two asterisks to indicate that it is a basis row even though it does not contain the sole entry of any column.

The choice of basis rows to supplement the single asterisk rows becomes more complicated when several columns (such as columns 2, 3, and 6 in Table VI(a)) remain to be lined out. The first step in choosing these supplementary basis rows is to determine whether any pairs of rows exist such that one row has crosses only in columns in which the

TABLE V — DETERMINATION OF THE MINIMUM SUM FOR

$$T = \sum (0, 1, 2, 3, 7, 14, 15, 22, 23, 29, 31)$$

(a) Determination of Prime Implicants

$x_3x_4x_2x_1$	$x_3x_4x_2x_1$	$x_3x_4x_2x_1$
0 0 0 0 0 ✓	0 1 0 0 0 - ✓	0 1 2 3 0 0 0 - -
1 0 0 0 0 1 ✓	0 2 0 0 0 - 0 ✓	7 15 23 31 - - 1 1 1
2 0 0 0 1 0 ✓	1 3 0 0 0 - 1 ✓	
3 0 0 0 1 1 ✓	2 3 0 0 0 1 - ✓	
7 0 0 1 1 1 ✓	3 7 0 0 - 1 1	
14 0 1 1 1 0 ✓	7 15 0 - 1 1 1 ✓	
22 1 0 1 1 0 ✓	7 23 - 0 1 1 1 ✓	
15 0 1 1 1 1 ✓	14 15 0 1 1 1 -	
23 1 0 1 1 1 ✓	22 23 1 0 1 1 -	
29 1 1 1 0 1 ✓	15 31 - 1 1 1 1 ✓	
31 1 1 1 1 1 ✓	23 31 1 - 1 1 1 ✓	
	29 31 1 1 1 - 1	

(b) First Step in Selection of Basis Rows

	0	1	2	3	7	14	22	15	23	29	31	
A	x	x	x	x								*
B					x			x	x		x	**
C										x	x	*
D							x		x			*
E						x		x				*
F				x	x							*

(c) Minimum Sum

$$T = \sum [(0, 1, 2, 3), (7, 15, 23, 31), (29, 31), (22, 23), (14, 15)]$$

$$T = x_3'x_4'x_2' + x_3x_2x_1 + x_3x_4x_2x_1 + x_3x_4'x_2x_1 + x_3'x_4x_2x_2$$

other member of the pair has crosses. Crosses in lined-out columns are not considered. In Table VI(a), rows A and B and rows B and C are such pairs of rows since row B has crosses in columns 2, 3, and 6 and row A has a cross in column 6 and row C has crosses in columns 2 and 3. A convenient way to describe this situation is to say that row B covers rows A and C, and to write  $B \supset A$ ,  $B \supset C$ . If row i is selected as a supplementary basis row and row i is covered by row j, which has the same total number of crosses as row i, then it is possible to choose row j as a basis row instead of row i since row j has a cross in each column in which row i has a cross.

The next step is to line out any rows which are covered by other rows in the same partition of the table, rows A and C in Table VI(a). If any

TABLE VI — PRIME IMPLICANT TABLES FOR  
 $T = \sum (0, 1, 2, 3, 6, 7, 14, 22, 30, 33, 62, 64, 71, 78, 86)$

(a) Prime Implicant Table with Single Asterisk Rows and Corresponding Columns Lined Out

	0	1	2	64	3	6	33	7	14	22	30	71	78	86	62
A							x		x	x	x				
B		x			x	x		x							
C	x	x	x		x										
D											x				x
E										x				x	
F									x				x		
G															
H			x				x								
I	x			x											

(b) Prime Implicant Table with Rows which are Covered by Other Rows Lined Out

	0	1	2	64	3	6	33	7	14	22	30	71	78	86	62
A							x		x	x	x				
B			x		x	x		x							
C	x	x	x		x										
D											x				x
E										x				x	
F									x				x		
G															
H			x				x								
I	x			x											

column now contains only one cross which is not lined out, columns 2, 3, and 6 in Table VI(b), two asterisks are placed next to the row in which this cross occurs, row B in Table VI(b), and this row and all columns in which this row has crosses are lined out. The process of drawing a line through any row which is covered by another row and selecting each row which contains the only cross in a column is continued until it terminates. Either all columns will be lined out, in which case the rows marked with one or two asterisks are the basis rows, or each column will contain more than one cross and no row will cover another row. The latter situation is discussed in the following section.

6 PRIME IMPLICANT TABLES IN CYCLIC FORM

If the rows and columns of a table which are not lined out are such that every column has more than one cross and no row covers another row, as in Table VII(b), the table will be said to be in *cyclic form*, or, in short,



TABLE VII — DETERMINATION OF BASIS ROWS FOR A CYCLIC PRIME IMPLICANT TABLE

<p>(a) Selection of Single Asterisk Rows</p> <p style="text-align: center;">0 4 16 12 24 19 28 27 29 31</p> <table border="1" style="width: 100%; border-collapse: collapse; text-align: center;"> <tr><td>A</td><td>x</td><td>x</td><td></td><td></td><td></td><td></td><td></td><td></td><td></td></tr> <tr><td>B</td><td>x</td><td></td><td>x</td><td></td><td></td><td></td><td></td><td></td><td></td></tr> <tr><td>C</td><td></td><td>x</td><td></td><td>x</td><td></td><td></td><td></td><td></td><td></td></tr> <tr><td>D</td><td></td><td></td><td>x</td><td></td><td>x</td><td></td><td></td><td></td><td></td></tr> <tr><td>E</td><td></td><td></td><td></td><td>x</td><td></td><td></td><td></td><td></td><td></td></tr> <tr><td>F</td><td></td><td></td><td></td><td></td><td>x</td><td></td><td></td><td></td><td></td></tr> <tr><td>G</td><td></td><td></td><td></td><td></td><td></td><td>x</td><td></td><td></td><td></td></tr> <tr><td>H</td><td></td><td></td><td></td><td></td><td></td><td></td><td>x</td><td></td><td></td></tr> <tr><td>I</td><td></td><td></td><td></td><td></td><td></td><td></td><td></td><td>x</td><td></td></tr> <tr><td>J</td><td></td><td></td><td></td><td></td><td></td><td></td><td></td><td></td><td>x</td></tr> </table>	A	x	x								B	x		x							C		x		x						D			x		x					E				x						F					x					G						x				H							x			I								x		J									x	<p>(b) Selection of Double Asterisk Rows</p> <p style="text-align: center;">0 4 16 12 24 19 28 27 29 31</p> <table border="1" style="width: 100%; border-collapse: collapse; text-align: center;"> <tr><td>A</td><td>x</td><td>x</td><td></td><td></td><td></td><td></td><td></td><td></td><td></td></tr> <tr><td>B</td><td>x</td><td></td><td>x</td><td></td><td></td><td></td><td></td><td></td><td></td></tr> <tr><td>C</td><td></td><td>x</td><td></td><td>x</td><td></td><td></td><td></td><td></td><td></td></tr> <tr><td>D</td><td></td><td></td><td>x</td><td></td><td>x</td><td></td><td></td><td></td><td></td></tr> <tr><td>E</td><td></td><td></td><td></td><td>x</td><td></td><td></td><td></td><td></td><td></td></tr> <tr><td>F</td><td></td><td></td><td></td><td></td><td>x</td><td></td><td></td><td></td><td></td></tr> <tr><td>G</td><td></td><td></td><td></td><td></td><td></td><td>x</td><td></td><td></td><td></td></tr> <tr><td>H</td><td></td><td></td><td></td><td></td><td></td><td></td><td>x</td><td></td><td></td></tr> <tr><td>I</td><td></td><td></td><td></td><td></td><td></td><td></td><td></td><td>x</td><td></td></tr> <tr><td>J</td><td></td><td></td><td></td><td></td><td></td><td></td><td></td><td></td><td>x</td></tr> </table>	A	x	x								B	x		x							C		x		x						D			x		x					E				x						F					x					G						x				H							x			I								x		J									x
A	x	x																																																																																																																																																																																																							
B	x		x																																																																																																																																																																																																						
C		x		x																																																																																																																																																																																																					
D			x		x																																																																																																																																																																																																				
E				x																																																																																																																																																																																																					
F					x																																																																																																																																																																																																				
G						x																																																																																																																																																																																																			
H							x																																																																																																																																																																																																		
I								x																																																																																																																																																																																																	
J									x																																																																																																																																																																																																
A	x	x																																																																																																																																																																																																							
B	x		x																																																																																																																																																																																																						
C		x		x																																																																																																																																																																																																					
D			x		x																																																																																																																																																																																																				
E				x																																																																																																																																																																																																					
F					x																																																																																																																																																																																																				
G						x																																																																																																																																																																																																			
H							x																																																																																																																																																																																																		
I								x																																																																																																																																																																																																	
J									x																																																																																																																																																																																																
<p>(c) Selection of Row 1 as a Trial Basis Row (Column 0)</p> <p style="text-align: center;">0 4 16 12 24 19 28 27 29 31</p> <table border="1" style="width: 100%; border-collapse: collapse; text-align: center;"> <tr><td>A</td><td>x-x</td><td></td><td></td><td></td><td></td><td></td><td></td><td></td><td></td></tr> <tr><td>B</td><td>x</td><td>x</td><td></td><td></td><td></td><td></td><td></td><td></td><td></td></tr> <tr><td>C</td><td>x</td><td></td><td>x</td><td></td><td></td><td></td><td></td><td></td><td></td></tr> <tr><td>D</td><td></td><td>x</td><td></td><td>x</td><td></td><td></td><td></td><td></td><td></td></tr> <tr><td>E</td><td></td><td></td><td>x</td><td></td><td>x</td><td></td><td></td><td></td><td></td></tr> <tr><td>F</td><td></td><td></td><td></td><td>x</td><td></td><td></td><td></td><td></td><td></td></tr> <tr><td>G</td><td></td><td></td><td></td><td></td><td>x</td><td></td><td></td><td></td><td></td></tr> <tr><td>H</td><td></td><td></td><td></td><td></td><td></td><td>x</td><td></td><td></td><td></td></tr> <tr><td>I</td><td></td><td></td><td></td><td></td><td></td><td></td><td>x</td><td></td><td></td></tr> <tr><td>J</td><td></td><td></td><td></td><td></td><td></td><td></td><td></td><td>x-x</td><td></td></tr> </table>	A	x-x									B	x	x								C	x		x							D		x		x						E			x		x					F				x						G					x					H						x				I							x			J								x-x		<p>(d) Selection of Row 2 as a Trial Basis Row (Column 0)</p> <p style="text-align: center;">0 4 16 12 24 19 28 27 29 31</p> <table border="1" style="width: 100%; border-collapse: collapse; text-align: center;"> <tr><td>A</td><td>x-x</td><td></td><td></td><td></td><td></td><td></td><td></td><td></td><td></td></tr> <tr><td>B</td><td>x</td><td>x</td><td></td><td></td><td></td><td></td><td></td><td></td><td></td></tr> <tr><td>C</td><td>x</td><td></td><td>x</td><td></td><td></td><td></td><td></td><td></td><td></td></tr> <tr><td>D</td><td></td><td>x</td><td></td><td>x</td><td></td><td></td><td></td><td></td><td></td></tr> <tr><td>E</td><td></td><td></td><td>x</td><td></td><td>x</td><td></td><td></td><td></td><td></td></tr> <tr><td>F</td><td></td><td></td><td></td><td>x</td><td></td><td></td><td></td><td></td><td></td></tr> <tr><td>G</td><td></td><td></td><td></td><td></td><td>x</td><td></td><td></td><td></td><td></td></tr> <tr><td>H</td><td></td><td></td><td></td><td></td><td></td><td>x</td><td></td><td></td><td></td></tr> <tr><td>I</td><td></td><td></td><td></td><td></td><td></td><td></td><td>x</td><td></td><td></td></tr> <tr><td>J</td><td></td><td></td><td></td><td></td><td></td><td></td><td></td><td>x-x</td><td></td></tr> </table>	A	x-x									B	x	x								C	x		x							D		x		x						E			x		x					F				x						G					x					H						x				I							x			J								x-x	
A	x-x																																																																																																																																																																																																								
B	x	x																																																																																																																																																																																																							
C	x		x																																																																																																																																																																																																						
D		x		x																																																																																																																																																																																																					
E			x		x																																																																																																																																																																																																				
F				x																																																																																																																																																																																																					
G					x																																																																																																																																																																																																				
H						x																																																																																																																																																																																																			
I							x																																																																																																																																																																																																		
J								x-x																																																																																																																																																																																																	
A	x-x																																																																																																																																																																																																								
B	x	x																																																																																																																																																																																																							
C	x		x																																																																																																																																																																																																						
D		x		x																																																																																																																																																																																																					
E			x		x																																																																																																																																																																																																				
F				x																																																																																																																																																																																																					
G					x																																																																																																																																																																																																				
H						x																																																																																																																																																																																																			
I							x																																																																																																																																																																																																		
J								x-x																																																																																																																																																																																																	

to be *cyclic*. If any column has crosses in only two rows, at least one of these rows must be included in any set of basis rows. Therefore, the basis rows for a cyclic table can be discovered by first determining whether any column contains only two crosses, and if such a column exists, by then selecting as a trial basis row one of the rows in which the crosses of this column occur. If no column contains only two crosses, then a column which contains three crosses is selected, etc. All columns in which the trial basis row has crosses are lined out and the process of lining out rows which are covered by other rows and selecting each row which contains the only cross of some column is carried out as described above. Either all columns will be lined out or another cyclic table will result. Whenever a cyclic table occurs, another trial row must be selected. Eventually all columns will be lined out. However, there is no guarantee that the selected rows are actually basis rows. The possibility exists that a different choice of trial rows would have resulted in fewer selected rows. In general, it is necessary to carry out the procedure of selecting rows several times, choosing different trial rows each time, so

that all possible combinations of trial rows are considered. The set of fewest selected rows is the actual set of basis rows.

Table VII illustrates the process of determining basis rows for a cyclic prime implicant table. After rows G and J have been selected a cyclic table results, Table VII(b). Rows A and B are then chosen as a pair of trial basis rows since column 0 has crosses in only these two rows. The selection of row A leads to the selection of rows D and E as given in Table VII(c). Row A is marked with three asterisks to indicate that it is a trial basis row. Table VII(d) illustrates the fact that the selection of rows C and F is brought about by the selection of row B. Since both sets of selected rows have the same number of rows (5) they are both sets of basis rows. Each set of basis rows corresponds to a different minimum sum so that there are two minimum sums for this function.

Sometimes it is not necessary to determine all minimum sums for the transmission being considered. In such cases, it may be possible to shorten the process of determining basis rows. Since each column must have a cross in some basis row, the total number of crosses in all of the basis rows is equal to or greater than the number of columns. Therefore, the number of columns divided by the greatest number of crosses in any row (or the next highest integer if this ratio is not an integer) is equal to the fewest possible basis rows. For example, in Table VII there are ten columns and two crosses in each row. Therefore, there must be at least 10 divided by 2 or 5 rows in any set of basis rows. The fact that there are only five rows selected in Table VII(c) guarantees that the selected rows are basis rows and therefore Table VII(d) is unnecessary if only one minimum sum is required. In general, the process of trying different combinations of trial rows can be stopped as soon as a set of selected rows which contains the fewest possible number of basis rows has been found (providing that it is not necessary to discover *all* minimum sums). It should be pointed out that more than the minimum number of basis rows may be required in some cases and in these cases all combinations of trial rows must be considered. A more accurate lower bound on the number of basis rows can be obtained by considering the number of rows which have the most crosses. For example, in Table VI there are 15 columns and 4 crosses, at most, in any row. A lower bound of  $4 \left(\frac{15}{4} = 3\frac{3}{4}\right)$  is a little too optimistic since there are only three rows which contain four crosses. A more realistic lower bound of 5 is obtained by noting that the rows which have 4 crosses can provide crosses in at most 12 columns and that at least two additional rows containing two crosses are necessary to provide crosses in the three remaining columns.

## 7 CYCLIC PRIME IMPLICANT TABLES AND GROUP INVARIANCE

It is not always necessary to resort to enumeration in order to determine all minimum sums for a cyclic prime implicant table. Often there is a simple relation among the various minimum sums for a transmission so that they can all be determined directly from any single minimum sum by simple interchanges of variables. The process of selecting basis rows for a cyclic table can be shortened by detecting beforehand that the minimum sums are so related.

An example of a transmission for which this is true is given in Table VIII. If the variables  $x_1$  and  $x_2$  are interchanged, one of the minimum sums is changed into the other. In the prime implicant table the interchange of  $x_1$  and  $x_2$  leads to the interchange of columns 1 and 2, 5 and 6, 9 and 10, 13 and 14, and rows A and B, C and D, E and F, G and H. The transmission itself remains the same after the interchange.

In determining the basis rows for the prime implicant table, Table VIII(d), either row G or row H can be chosen as a trial basis row. If row G is selected the i-set of basis rows will result and if row H is selected the ii-set of basis rows will result. It is unnecessary to carry out the procedure of determining both sets of basis rows. Once the i-set of basis rows is known, the ii-set can be determined directly by interchanging the  $x_1$  and  $x_2$  variables in the i-set. Thus no enumeration is necessary in order to determine all minimum sums.

In general, the procedure for a complex prime implicant table is to determine whether there are any pairs of variables which can be interchanged without effecting the transmission. If such pairs of variables exist, the corresponding interchanges of pairs of rows are determined. A trial basis row is then selected from a pair of rows which contain the only two crosses of a column and which are interchanged when the variables are permuted. After the set of basis rows has been determined, the other set of basis rows can be obtained by replacing each basis row by the row with which it is interchanged when variables are permuted. If any step of this procedure is not possible, it is necessary to resort to enumeration.

In the preceding discussion only simple interchanges of variables have been mentioned. Actually all possible permutations of the contact variables should be considered. It is also possible that priming variables or both priming and permuting them will leave the transmission unchanged. For example, if  $T = x_4 x_3' x_2 x_1' + x_4' x_3 x_2' x_1$ , priming all the variables leaves the function unchanged. Also, priming  $x_4$  and  $x_3$  and then interchanging  $x_4$  and  $x_3$  does not change the transmission. The general name for this property is *group invariance*. This was discussed by Shannon.<sup>4</sup>

A method for determining the group invariance for a specified transmission is presented in "Detection of Group Invariance or Total Symmetry of a Boolean Function."\*

#### 8 AN APPROXIMATE SOLUTION FOR CYCLIC PRIME IMPLICANT TABLES

It has not been possible to prove in general that the procedure presented in this section will always result in a minimum sum. However, this procedure should be useful when a reasonable approximation to a minimum sum is sufficient, or when it is possible to devise a proof to show that the procedure does lead to a minimum sum for a *specific transmission* (such proofs were discussed in Section 6). Since this procedure is much simpler than enumeration, it should generally be tested before resorting to enumeration.

The first step of the procedure is to select from the prime implicant table a set of rows such that (1) in each column of the table there is a cross from at least one of the selected rows and (2) none of the selected rows can be discarded without destroying property (1). Any set of rows having these properties will be called a *consistent row set*. Each consistent row set corresponds to a sum of products expression from which no product term can be eliminated directly by any of the theorems of Boolean Algebra. In particular, the consistent row sets having the fewest members correspond to minimum sums. The first step of the procedure to be described here is to select a consistent row-set. This is done by choosing one of the columns, counting the total number of crosses in each row which has a cross in this column, and then selecting the row with the most crosses. If there is more than one such row, the topmost row is arbitrarily selected. The selected row is marked with a check. In Table IX, column 30 was chosen and then row A was selected since rows A and Z each have a cross in column 30, but row A has 4 crosses while row Z has only 2 crosses. The selected row and each column in which it has a cross is then lined out. The process just described is repeated by selecting another column (which is not lined out). Crosses in lined-out columns are not counted in determining the total number of crosses in a row. The procedure is repeated until all columns are lined out.

The table is now rearranged so that all of the selected rows are at the top, and a line is drawn to separate the selected rows from the rest. Table X results from always choosing the rightmost column in Table IX. If any column contains only one cross from a selected row, the single selected-row cross is circled. Any selected row which does not have any

---

\* See page 1445 of this issue.

TABLE VIII — DETERMINATION OF THE MINIMUM SUMS FOR  
 $T = \sum (0, 1, 2, 5, 6, 7, 9, 10, 11, 13, 14, 15)$

(a)		(c)	
$x_4 x_3 x_2 x_1$		$x_4 x_3 x_2 x_1$	
0	0 0 0 0 ✓	1 5 9 13	- - 0 1
1	0 0 0 1 ✓	2 6 10 14	- - 1 0
2	0 0 1 0 ✓		
5	0 1 0 1 ✓	5 7 13 15	- 1 - 1
6	0 1 1 0 ✓	6 7 14 15	- 1 1 -
9	1 0 0 1 ✓	9 11 13 15	1 - - 1
10	1 0 1 0 ✓	10 11 14 15	1 - 1 -
7	0 1 1 1 ✓		
11	1 0 1 1 ✓		
13	1 1 0 1 ✓		
14	1 1 1 0 ✓		
15	1 1 1 1 ✓		

(b)		(d)	
$x_4 x_3 x_2 x_1$			
0, 1	0 0 0 -	0	1
0, 2	0 0 - 0	2	5
1, 5	0 - 0 1 ✓	6	9
1, 9	- 0 0 1 ✓	10	7
2, 6	0 - 1 0 ✓	11	13
2, 10	- 0 1 0 ✓	14	15
5, 7	0 1 - 1 ✓		
5, 13	- 1 0 1 ✓		
6, 7	0 1 1 - ✓		
6, 14	- 1 1 0 ✓		
9, 11	1 0 - 1 ✓		
9, 13	1 - 0 1 ✓		
10, 11	1 0 1 - ✓		
10, 14	1 - 1 0 ✓		
7, 15	- 1 1 1 ✓		
11, 15	1 - 1 1 ✓		
13, 15	1 1 - 1 ✓		
14, 15	1 1 1 - ✓		

	0	1	2	5	6	9	10	7	11	13	14	15
A	x			x		x				x		
B		x			x		x				x	
C			x					x		x		x
D				x			x				x	x
E					x			x	x	x		x
F						x			x		x	x
G	x	x										
H	x		x									

(e)	
(i)	(0, 1) + (2, 6, 10, 14) + (5, 7, 13, 15) + (9, 11, 13, 15)
(ii)	(0, 2) + (1, 5, 9, 13) + (6, 7, 14, 15) + (10, 11, 14, 15)
$T_i$	$= x_4'x_3'x_2' + x_2x_1' + x_3x_1 + x_4x_1$
$T_{ii}$	$= x_4'x_3'x_1' + x_1x_2' + x_3x_2 + x_4x_2$

of its crosses circled can be discarded without violating the requirement that each column should have at least one cross from a selected row. Rows with no circled entries are discarded (one by one, since removal of one row may require more crosses to be circled) until each selected row contains at least one circled cross. This completes the first step. The selected rows now correspond to a first approximation to a minimum sum. A check should be made to determine whether the number of selected rows is equal to the minimum number of basis rows. In Table X there are at most 4 crosses per row and 26 columns so that the minimum num-

TABLE IX — TABLE OF PRIME IMPLICANTS FOR TRANSMISSION

$$T = \sum (0, 1, 2, 4, 5, 6, 7, 8, 9, 11, 13, 14, 15, 16, 18, 19, 20, 21, 23, 24, 25, 26, 27, 28, 29, 30)$$

The selection of row A is shown

	0	1	2	4	5	6	9	18	20	24	7	11	13	14	19	21	25	26	28	15	23	27	29	30	
A									x									x	x					x	4
B									x										x	x					
C									x										x	x					
D									x										x	x					
E									x										x	x					
F									x										x	x					
G									x										x	x					
H									x										x	x					
I									x										x	x					
J									x										x	x					
K									x										x	x					
L									x										x	x					
M									x										x	x					
N									x										x	x					
O									x										x	x					
P									x										x	x					
Q									x										x	x					
R									x										x	x					
S									x										x	x					
T									x										x	x					
U									x										x	x					
V									x										x	x					
W									x										x	x					
X									x										x	x					
Y									x										x	x					
Z									x										x	x					2

ber of basis rows is  $\lceil \frac{26}{4} \rceil + 1 = 7$ . Since the number of selected rows is 9 there is no guarantee that they correspond to a minimum sum.

If such an approximation to a minimum sum is not acceptable, then further work is necessary in order to reduce the number of selected rows. For each of the selected rows, a check is made of whether any of the rows in the lower part of the table (non-selected rows) have crosses in all columns in which the selected row has circled crosses. In Table X row E has a circled cross only in column 19; since row Y also has a cross in column 19 rows E and Y are labeled "a". Other pairs of rows which have the same relation are labeled with lower case letters, b, c, d, e in Table X. It is possible to interchange pairs of rows which are labeled with the same lower case letter without violating the requirement that each column must contain a cross from at least one selected row. If a non-selected row is labeled with two lower case letters then it may be possible to replace two selected rows by this one non-selected row and thereby reduce the

TABLE X—TABLE IX AFTER PARTITIONING

	0	1	2	4	8	16	5	6	9	18	20	24	7	11	13	14	19	21	25	26	28	15	23	27	29	30	
A																											
E																											
F																											
G																											
I																											
K																											
T																											
U																											
W																											
B																											
C																											
D																											
H																											
J																											
L																											
M																											
N																											
O																											
P																											
Q																											
R																											
S																											
V																											
X																											
Y																											
Z																											

(a) (b) (c) (d) (e) (c) (b) (d) (e) (a)





total number of selected rows (a check must be made that the two selected rows being removed do not contain the only two selected-row crosses in a column). In Table X no such interchange is possible.

Next a check should be made as to whether two of the labeled non-selected rows can be used to replace three selected rows, etc. In Table X rows Y(a) and J(b) can replace rows E(a), F(b) and K or rows Y(a) and P(d) can replace rows E(a), T(d) and K. The table which results from replacing rows E, F and K by rows Y and J is given in Table XI. The number of selected rows is now 8 which is still greater than 7, the minimum number possible. This table actually represents the minimum sum for this transmission even though this cannot be proved rigorously by the procedure being described.

If it is assumed that a minimum sum can always be obtained by exchanging pairs of selected and nonselected rows until it finally becomes possible to replace two or more selected rows by a single selected row, then it is possible to show directly that the Table XI does represent a minimum sum. The only interchange possible in Table XI is that of rows T and P. If this replacement is made then a table results in which only rows J and F can be interchanged. Interchanging rows J and F does not lead to the possibility of interchanging any new pairs of rows so that this process cannot be carried any further.

On the basis of experience with this method it seems that it is not necessary to consider interchanges involving more than one non-selected row. Such interchanges have only been necessary in order to obtain alternate minimum sums; however, no proof for the fact that they are never required in order to obtain a minimum sum has yet been discovered.

## 9 AN ALTERNATE EXACT PROCEDURE

It is possible to represent the prime implicant table in an alternative form such as that given in Table XII(b). From this form not only the minimum sums but also *all* possible sum of products forms for the transmission which correspond to consistent row sets can be obtained systematically. For concreteness, this representation will be explained in terms of Table XII. Since column 0 has crosses only in rows B and C, any consistent row set must contain either row B or row C (or both). Similarly, column 3 requires that any consistent row set must contain either row D or row E (or both). When both columns 0 and 3 are considered they require that any consistent row set must contain either row B or row C (or both) and either row D or row E (or both). This requirement can be expressed symbolically as  $(B + C)(D + E)$  where

TABLE XII — DERIVATION OF THE MINIMUM SUMS FOR THE TRANSMISSION

$$T = \sum (0, 3, 4, 5, 6, 7, 8, 10, 11)$$

(a) Table of Prime Implicants

		0	3	4	5	6	7	8	10	11
$x_4'x_1$	A			x	x	x	x			
$x_4'x_2'x_1'$	B	x		x						
$x_3'x_2'x_1'$	C	x						x		
$x_4'x_3x_1$	D			x			x			
$x_3'x_2x_1$	E		x							x
$x_4x_3'x_2$	F								x	x

(b) Boolean Representation of Table

$$(B + C)(D + E)(A + B)(A)(A)(A + D)(C)(F)(E + F)$$

(c) Consistent Row Sets

$$(A, C, F, D), \quad (A, C, F, E)$$

$$T = x_4'x_3 + x_3'x_2'x_1' + x_4x_3'x_2 + x_4'x_2x_1$$

$$T = x_4'x_3 + x_3'x_2'x_1' + x_4x_3'x_2 + x_3'x_2x_1$$

addition stands for "or" (non-exclusive) and multiplication signifies "and." This expression can be interpreted as a Boolean Algebra expression and the Boolean Algebra theorems used to simplify it. In particular it can be "multiplied out":

$$(B + C)(D + E) = BD + BE + CD + CE$$

This form is equivalent to the statement that columns 0 and 3 require that any consistent row set must contain either rows B and D, or rows B and E, or rows C and D, or rows C and E.

The complete requirements for a consistent row set can be obtained directly by providing a factor for each column of the table. Thus for Table XII the requirements for a consistent row set can be written as:

$$(B + C)(D + E)(A + B)(A)(A)(A + D)(C)(F)(E + F)$$

By using the theorems that  $A \cdot (A + D) = A$  and  $A \cdot A = A$ , this can be simplified to  $ACF(D + E)$ . Thus the two consistent row sets for this table are A, C, F, D and A, C, F, E and since they both contain the same number of rows, they both represent minimum sums. This is true only because rows D and E contain the same number of crosses. In general, each row should be assigned a weight  $w = n - \log_2 k$ , where  $n$  is the number of variables in the transmission being considered and

TABLE XIII — DETERMINATION OF THE MINIMUM SUMS FOR THE PRIME IMPLICANT TABLE OF TABLE VII BY MEANS OF THE BOOLEAN REPRESENTATION

(a) Boolean representation of the Prime Implicant Table of Table VI  
 $(A+B)(A+C)(B+D)(C+E)(D+F)(G)(E+F+H)(G+I)(H+J)(I+J)$

(b) The expression of (a) after multiplying out. (The terms in *italic* correspond to minimum sums)

$$ADEJG + ACDFJG + ACDHJG + ADEHIG + ACDHIG + ABEFJG + ABEFHIG + BCDEJG + BCDHJG + BCDHIG + BCFJG + BCFHIG$$

(c) Tree circuit equivalent of (b)

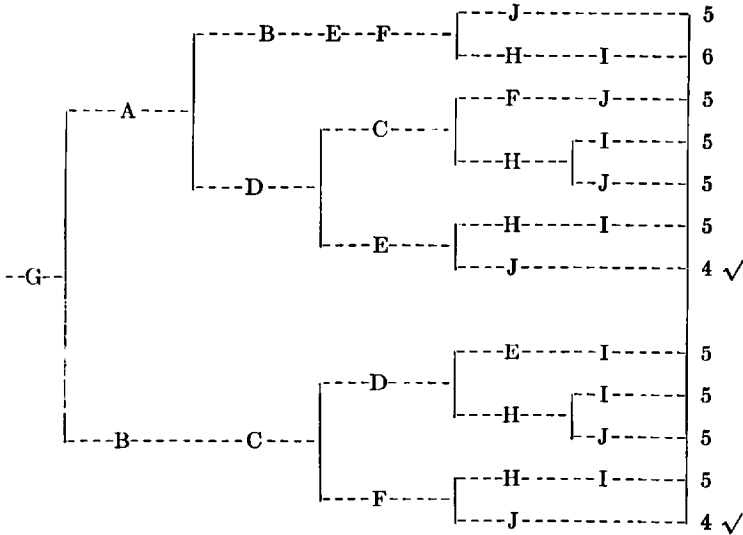

$k$  is the number of crosses in the row.\* To select the minimum sums, the sum of the weights of the rows should be calculated for each row set containing the fewest rows. The row sets having the smallest total weight correspond to minimum sums. If, instead of the minimum sum, the form leading to the two-stage diode-logic circuit requiring fewest diodes is desired, a slightly different procedure is appropriate. To each row set is assigned a total weight equal to the sum of the weights of the rows plus the number of rows in the set. The desired form then corresponds to the row set having the smallest total weight.

The procedure for an arbitrary table is analogous. A more complicated example is given in Table XIII. In this example the additional

\*  $n \cdot \log_2 k$  is the number of literals in the prime implicant corresponding to a row containing  $k$  crosses.

theorem  $(A + B)(A + C) = (A + BC)$  is useful. This example shows that for a general table the expressions described in this Section and the multiplication process can become very lengthy. However, this procedure is entirely systematic and may be suitable for mechanization.

Since the product of factors representation of a prime implicant table is a Boolean expression, it can be interpreted as the transmission of a contact network. Each consistent row set then corresponds to a path through this equivalent network. By sketching the network directly from the product of factors expression, it is possible to avoid the multiplication process. In particular the network should be sketched in the form of a tree, as in Table XIII(c) and the Boolean Algebra theorems used to simplify it as it is being drawn. For hand calculations, this method is sometimes easier than direct multiplication.

10 *d*-TERMS

In Section 1 the possibility of having *d*-entries in a table of combinations was mentioned. Whenever there are combinations of the relay conditions for which the transmission is not specified, *d*-entries are placed in the *T*-column of the corresponding rows of the table of combinations.

TABLE XIV — DETERMINATION OF THE MINIMUM SUM FOR THE TRANSMISSION

$$T = \sum(5, 6, 13) + d(9, 14) \text{ WHERE 9 AND 14 ARE THE } d\text{-TERMS}$$

(a) Determination of Prime Implicants

	$x_4 x_3 x_2 x_1$		$x_4 x_3 x_2 x_1$
5	0 1 0 1 ✓	5 13	- 1 0 1
6	0 1 1 0 ✓	6 14	- 1 1 0
(d) 9	1 0 0 1 ✓	9 13	1 - 0 1
-----			
13	1 1 0 1 ✓		
(d) 14	1 1 1 0 ✓		

(b) Prime Implicant Table

	5	6	13
*	x		x
*		x	
			x

(c)

Basis rows: (5, 13), (6, 14)

(d)

$$T = x_3 x_2' x_1 + x_3 x_2 x_1'$$

The actual values (0 or 1) of these  $d$ -entries are chosen so as to simplify the form of the transmission. This section will describe how to modify the method for obtaining a minimum sum when the table of combinations contains  $d$ -entries.

The  $p$ -terms which correspond to  $d$ -entries in the table of combinations will be called  $d$ -terms. These  $d$ -terms should be included in the list of  $p$ -terms which are used to form the prime implicants. See Table XIV. However, in forming the prime implicant table, columns corresponding to the  $d$ -terms should *not* be included, Table XIV(b). The  $d$ -terms are used in forming the prime implicants in order to obtain prime implicants containing the fewest possible literals. If columns corresponding to the  $d$ -terms were included in forming the prime implicant table this would correspond to setting all the  $d$ -entries in the table of combinations equal to 1. This does not necessarily lead to the simplest minimum sum. In the procedure just described, the  $d$ -entries will automatically be set equal to either 0 or 1 so as to produce the simplest minimum sum. For the transmission of Table XIV the 14  $d$ -entry has been set equal to 1 and the 9  $d$ -entry has been set equal to 0.

#### 11 NON-CANONICAL SPECIFICATIONS

A transmission is sometimes specified not by a table of combinations or a canonical expansion, but as a sum of product terms (not necessarily prime implicants). The method described in Section 3 is applicable to such a transmission if the appropriate table of combinations (decimal specification) is first obtained. However, it is possible to modify the procedure to make use of the fact that the transmission is already partly reduced. The first step is to express the transmission in a table of binary characters such as Table XVa. Then each pair of characters is examined to determine whether any different character could have been formed from the characters used in forming the characters of the pair. For example, in Table XV(a) a (1)(00001) was used in forming the (0, 1)(0000-) character and a (3)(00011) was used in forming the (3, 7)(00-11) character. These can be combined to form a new character (1, 3)(000-1). The new characters formed by this process are listed in another column such as Table XV(b). This process is continued until no new characters are formed.

In examining a pair of characters, it is sufficient to determine whether there is only one position where one character has a one and the other character has a zero. If this is true a new character is formed which has a dash in this position and any other position in which both characters have dashes, and has a zero (one) in any position in which either charac-

TABLE XV — DETERMINATION OF THE PRIME IMPLICANTS FOR THE TRANSMISSION OF TABLE XV SPECIFIED AS A SUM OF PRODUCT TERMS

(a) Specification					(b) Characters Derived from (a)										
		$x_5$	$x_4$	$x_3$	$x_2$	$x_1$			$x_5$	$x_4$	$x_3$	$x_2$	$x_1$		
0	1	0	0	0	0	-	✓	1	3	0	0	0	-	✓	
0	2	0	0	0	-	0	✓	2	3	0	0	0	1	-	✓
3	7	0	0	-	1	1		7	15	0	-	1	1	1	✓
14	15	0	1	1	1	-		7	23	-	0	1	1	1	✓
22	23	1	0	1	1	-		15	31	-	1	1	1	1	✓
29	31	1	1	1	-	1		23	31	1	-	1	1	1	✓

(c) Characters Derived from (a) and (b)													
		$x_5$	$x_4$	$x_3$	$x_2$	$x_1$			$x_5$	$x_4$	$x_3$	$x_2$	$x_1$
0	1	2	3					0	0	0	-	-	
7	15	23	31					-	-	1	1	1	

ter has a zero (one). In Table XVa the (0, 1) character has a zero in the  $x_2$ -position while the (3, 7) character has a one in the  $x_2$ -position. A new character is formed (1, 3) which has a dash in the  $x_2$ -position.

This rule for constructing new characters is actually a generalization of the rule used in Section 3 and corresponds to the theorem.

$$x_1x_2 + x_1'x_3 = x_1x_2 + x_1'x_3 + x_2x_3.$$

Repeated application of this rule will lead to the complete set of prime implicants. As described in Section 3, any character which has all of the numbers of its decimal label appearing in the label of another character should be checked. The unchecked characters then represent the prime implicants. The process described in this section was discussed from a slightly different point of view by Quine.<sup>7</sup>

12 SUMMARY AND CONCLUSIONS

In this paper a method has been presented for writing any transmission as a minimum sum. This method is similar to that of Quine; however, several significant improvements have been made. The notation has been simplified by using the symbols 0, 1 and - instead of primed and unprimed variables. While it is not completely new in itself, this notation is especially appropriate for the arrangement of terms used in determining the prime implicants. Listing the terms in a column which is partitioned so as to place terms containing the same number of 1's in the same partition reduces materially the labor involved in determining the prime implicants. Such a list retains some of the advantage of the arrangement of squares in the Karnaugh Chart without requiring a geometrical representation of an  $n$ -dimensional hypercube. Since the

procedure for determining the prime implicants is completely systematic it is capable of being programmed on a digital computer. The arrangement of terms introduced here then results in a considerable saving in both time and storage space over previous methods, making it possible to solve larger problems on a given computer. It should be pointed out that this procedure can be programmed on a decimal machine by using the decimal labels instead of the binary characters introduced.

A method was presented for choosing the minimum sum terms from the list of prime implicants by means of a table of prime implicants. This is again similar to a method presented by Quine. However, Quine did not give any systematic procedure for handling cyclic prime implicant tables; that is, tables with more than one cross in each column. In this paper a procedure is given for obtaining a minimum sum from a cyclic prime implicant table. In general, this procedure requires enumeration of several possible minimum sums. If a transmission has any nontrivial group invariances it may be possible to avoid enumeration or to reduce considerably the amount of enumeration necessary. A method for doing this is given.

The process of enumeration used for selecting the terms of the minimum sum from a cyclic prime implicant table is not completely satisfactory since it can be quite lengthy. In seeking a procedure which does not require enumeration, the method involving the group invariances of a transmission was discovered. This method is an improvement over complete enumeration, but still has two shortcomings. There are transmissions which have no nontrivial group invariances but which give rise to cyclic prime implicant tables. For such transmissions it is still necessary to resort to enumeration. Other transmissions which do possess nontrivial group invariances still require enumeration after the invariances have been used to simplify the process of selecting minimum sum terms. More research is necessary to determine some procedure which will not require any enumeration for cyclic prime implicant tables. Perhaps the concept of group invariance can be generalized so as to apply to all transmissions which result in cyclic prime implicant tables.

### 13 ACKNOWLEDGEMENTS

The author wishes to acknowledge his indebtedness to Professor S. H. Caldwell, Professor D. A. Huffman, Professor W. K. Linvill, and S. H. Unger with whom the author had many stimulating discussions. Thanks are due also to W. J. Cadden, C. Y. Lee, and G. H. Mealy for their helpful comments on the preparation of this paper.

This research was supported in part by the Signal Corps; the Office of Scientific Research, Air Research and Development Command; and the Office of Naval Research.

## BIBLIOGRAPHY

1. Karnaugh, M., The Map Method for Synthesis of Combinational Logic Circuits, *Trans. A.I.E.E.*, **72**, Part I pp. 593-598, 1953.
2. Keister, W., Ritchie, A. E., Washburn, S., *The Design of Switching Circuits*, New York, D. Van Nostrand Company, Inc., 1951.
3. Shannon, C. E., A Symbolic Analysis of Relay and Switching Circuits, *Trans. A.I.E.E.*, **57**, pp. 713-723, 1938.
4. Shannon, C. E., The Synthesis of Two-Terminal Switching Circuits, *B.S.T.J.*, **28**, pp. 59-98, 1949.
5. Staff of the Harvard Computation Laboratory, *Synthesis of Electronic Computing and Control Circuits*, Cambridge, Mass., 1951, Harvard University Press.
6. Quine, W. V., The Problem of Simplifying Truth Functions, *The American Mathematical Monthly*, **59**, No. 8, pp. 521-531, Oct., 1952.
7. Quine, W. V., A Way to Simplify Truth Functions, *The American Mathematical Monthly*, **62**, pp. 627-631, Nov., 1955.